

# Multifunction Touch Panel

**BSV-CHTSD-01**

Technical Specifications

[www.chemito.net](http://www.chemito.net)

DRAFT

## Multi-Functions Touch Panel

### BSV-CHTSD-01



### Overview

BSV-CHTSD-01 is a control panel used for bus intelligent dispatch system. Adopted with 18 buttons, 7 inches large screen display, it can operate the MDVR menu.

Besides, when the driver reverses the bus, it automatically switches from normal recording to the reversing live view. It also integrates with features of SMS and voice broadcast. Moreover, it can realize the functions of speaking inside/outside of the vehicle, IP connection and making calls. It is widely applied to domestic and overseas bus systems for its easy installation, powerful features and convenient operation.

### Features

- 7 inches touch screen display
- Supports for MDVR diagnosis and operation
- Built-in speakers
- Built-in RFID module to sign in/out
- Resolution 800\*480
- Station announcement (Manually and automatically)

## Technical Specification of BSV-CHTSD-01

Items	Parameter	Performance Index
<b>Specifications of Screen</b>	Size	7 Inches
	Resolution	800*480
	Aspect ratio	16:9
	Button and Screen Distribution	Combined
<b>Material</b>	Panel Material	70%PC+30%ABS Engineering plastics
	Button Material	Silicone
<b>Built-in Module</b>	RFID Wipe Card Module	13.56 MHZ for driver to sign in and sign off.
	Speaker	Speaker(16Ω, 2W)x2
<b>Interface</b>	MDVR Interface	Connects to Chemito MDVR
	CAM Interface	Yellow 4PIN aviation-din connector, connects to reversing camera
	MIC Interface	Connects to the driver megaphone
	SENSOR Interface	Yellow hanging line, reversing signal detection port, high level effective. To monitor control for reversing.
<b>Button</b>	Function Buttons	Restate / station announcer / Arrow Keys / Confirmation / Exit
	Number Buttons	0-9
<b>Functionality</b>	Live view and play back	
<b>Installation</b>	Tile Installation	Refer to mounting bracket.
	Bracket Installation	There are three brackets with hood.
<b>Dimension</b>	185mm×128mm×34.9mm	
<b>Operation Parameters</b>	Operating Voltage	12V (Through mNVR)
	Operating Current	200mA
	Total Power Consumption	2.4W
<b>Performance Parameters</b>	Waterproof and Dust proof	IP65
	Operating Temperature	-20°C~+70°C ;
	Relative Humidity	Upto 90%
	Weight	750 gm

## Specification of LCD

LCD Parameter	Performance Index	Description
Screen Type	LCD screen	
Touch Type	4 wire resistor type	
Size	7 inch	
Resolution	800*480	
Luminance	400cd/m2	
Contrast Ratio	20:1	Under a suitable brightness condition, the higher contrast, the richer color levels
Response Time	10/15(Tr/Td) ms	The response time of the LCD to the input signal
Visual Angle	75/75/75/75 (Typ.)(CR dot 10)(Left/Right/Up/Down)	
Maximum Number of Display Color	262K/16.7M(6bit/6bit+Dithering)	
Scale	16:9	
Back-light Type	White LED	Adjustable Backlight off time

## Dimension and Pin Definition (unit: mm)

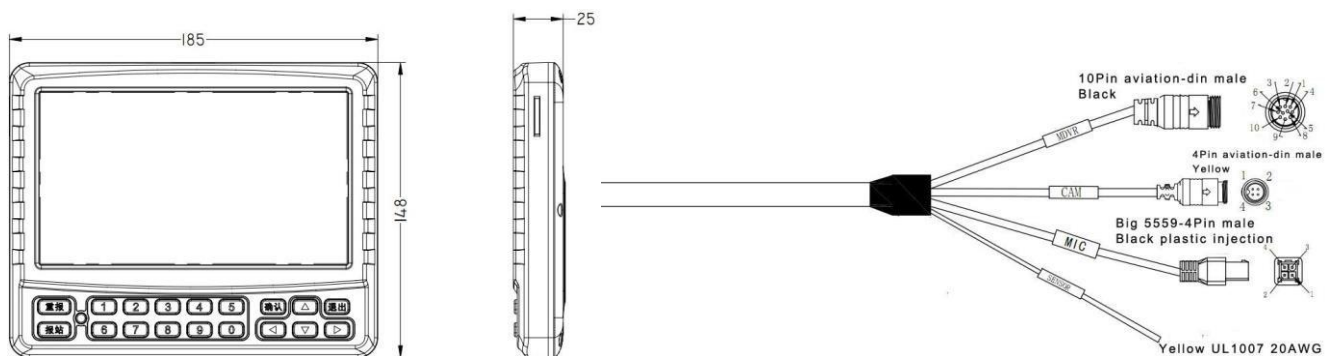

Connector Name	Function	Definition
MDVR	Black 10PIN aviation-din male connector connects to Chemito MDVR.	
CAM	Yellow 4PIN aviation-din connector connects to reversing camera.	
MIC	Connects to driver microphone.	

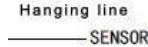
<b>SENSOR</b>	Yellow hanging line, reversing signal detection port, high level effective. For reversing control.	 <p>Hanging line —— SENSOR</p>
---------------	--	--

## Bracket Installation

(BSV-CHTSD-01 supports bracket installation, and there are three brackets to be chosen)

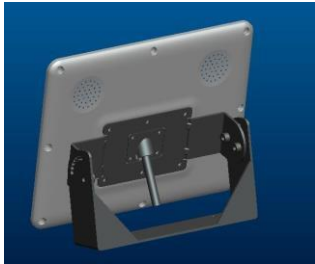

Suitable for relatively flat console



Suitable for curved console



Suitable for hanging

\*Subject to change without prior notice

An ISO9001:2015 Certified Company